



# **OTS BATTERYLESS RFID LOCK**

INSTALLATION AND ASSEMBLY - V1.2

**TABLE OF CONTENT**

**1. GENERAL RECOMMENDATIONS AND INSTRUCTIONS FOR USE .....3**

**2. FIXING HOLES MACHINING .....4**

**2.1 LOCK DIRECTION .....4**

**2.2 PHENOLIC MATERIAL .....5**

**2.3 CHIPBOARD MATERIAL .....5**

**3. FITTING INSTRUCTIONS .....6**

## 1. GENERAL RECOMMENDATIONS AND INSTRUCTIONS FOR USE

To ensure the correct operation of our product in your installations you must follow the following rules:

1. Product installation and use must be carried out in accordance with the technical operating conditions described in the corresponding manual.
2. When not specifically indicated the proper installation and use of the application is the responsibility of the customer.
3. Inspect the packaging and material for damage immediately after reception of the material. Additionally check that the delivery is complete (accessories, documentation, etc.)
4. If the packaging has been damaged during transport or you suspect that it could have been damaged or may be faulty, the material must not be started up. In this case, please contact us.
5. Our products' installation and handling must be carried out by authorised staff. The electrical connections in particular must be carried out only by qualified specialists.
6. Any replacement or removal of the protection covers is strictly forbidden.
7. Do not attempt to repair materials after a fault or damage and try to operate it again. In such an event, it is essential you contact us.
8. We take no responsibility for damage caused as the result of misuse.



## 2. FIXING HOLES MACHINING

The OTS Batteryless can be installed in lockers up to 20 mm thick.

### 2.1 LOCK DIRECTION

Lock assembly depending on if it is right-handed or left-handed is shown in Figure 1.

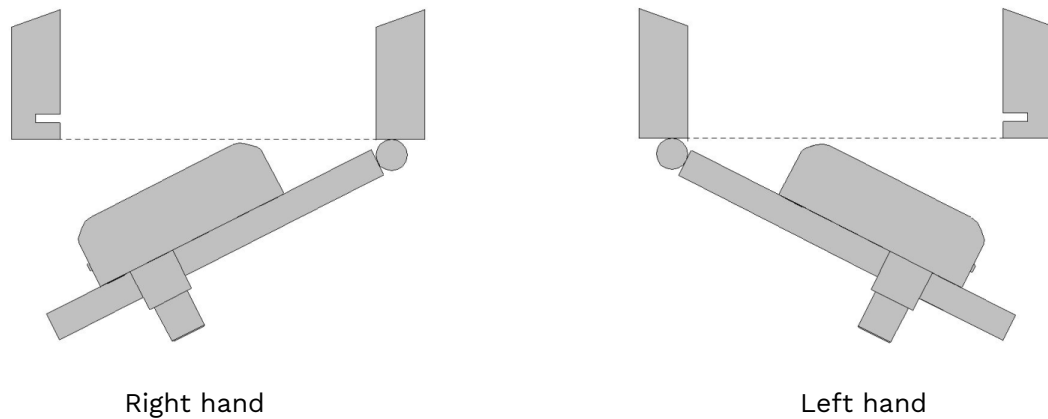

*Figure 1. Representation of right and left handed lock.*

In order to avoid assembly problems of the lock (the cam may get stuck, the knob may seize, etc.), it is necessary that the fixing holes in the door are drilled during the machining process of the door. The dimensions and positions of these holes are shown below in Figures 2 and 3, depending on the door material.

**ATTENTION:** Ojmar is not responsible for any problems that may occur in the assembly of the locks due to the non-machining of the lock fixing holes.

## 2.2 PHENOLIC MATERIAL

**Inside view of the door.** All dimensions in mm (inches). The depth of the 4 holes depends on the thickness of the door. The hole diameter for the knob must be 26 mm (+1/0 mm) and bevelling the hole on the inner area of the door is recommended.

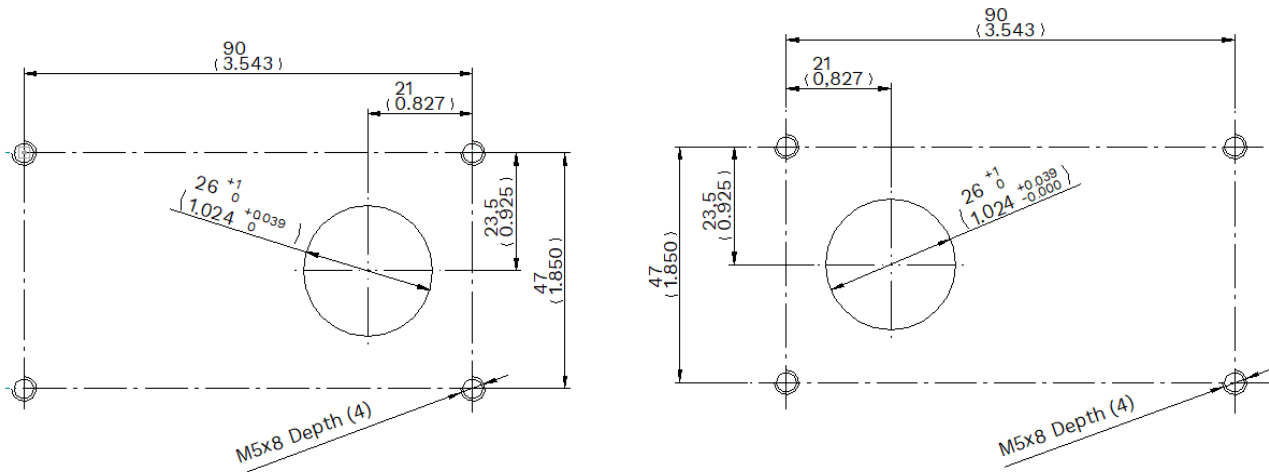

Figure 2. Position and sizes of the door hole. Phenolic material.

## 2.3 CHIPBOARD MATERIAL

**Inside view of the door.** All dimensions in mm (inches). The depth of the 4 holes depends on the thickness of the door. The hole diameter for the knob must be 26 mm (+1/0 mm) and bevelling the hole on the inner area of the door is recommended.

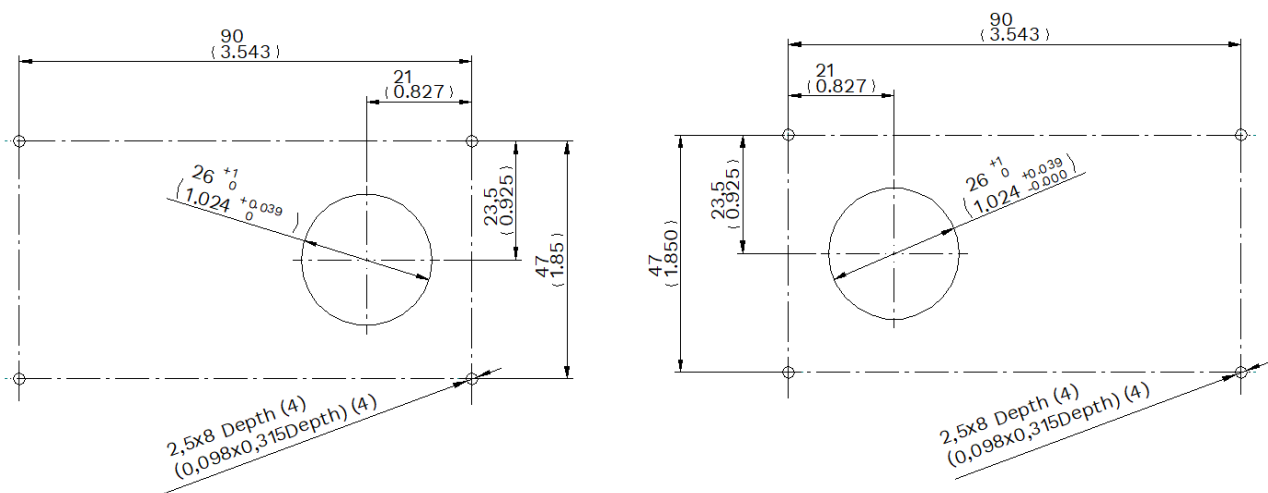

Figure 3. Position and sizes of the door holes. Chipboard material.

### 3. FITTING INSTRUCTIONS

The OTS Batteryless lock is fixed to the locker door with four screws.

1. Recommended screws:
  - Wooden doors: Coach nut 4.5 x 35 (depending on the thickness of the door).
  - Phenolic (HPL) or metal doors: Raised countersunk screw Philips M5 x 35 (depending on the thickness of the door).
2. The maximum tightening torque to apply to the tightening of each screw or coach nut will be 300 Ncm.

**(\*) NOTE:** During installation, ensure that the lock does not collide with the locker body with the door open. The dimensions and location of the fixing holes are shown in Figure 4.

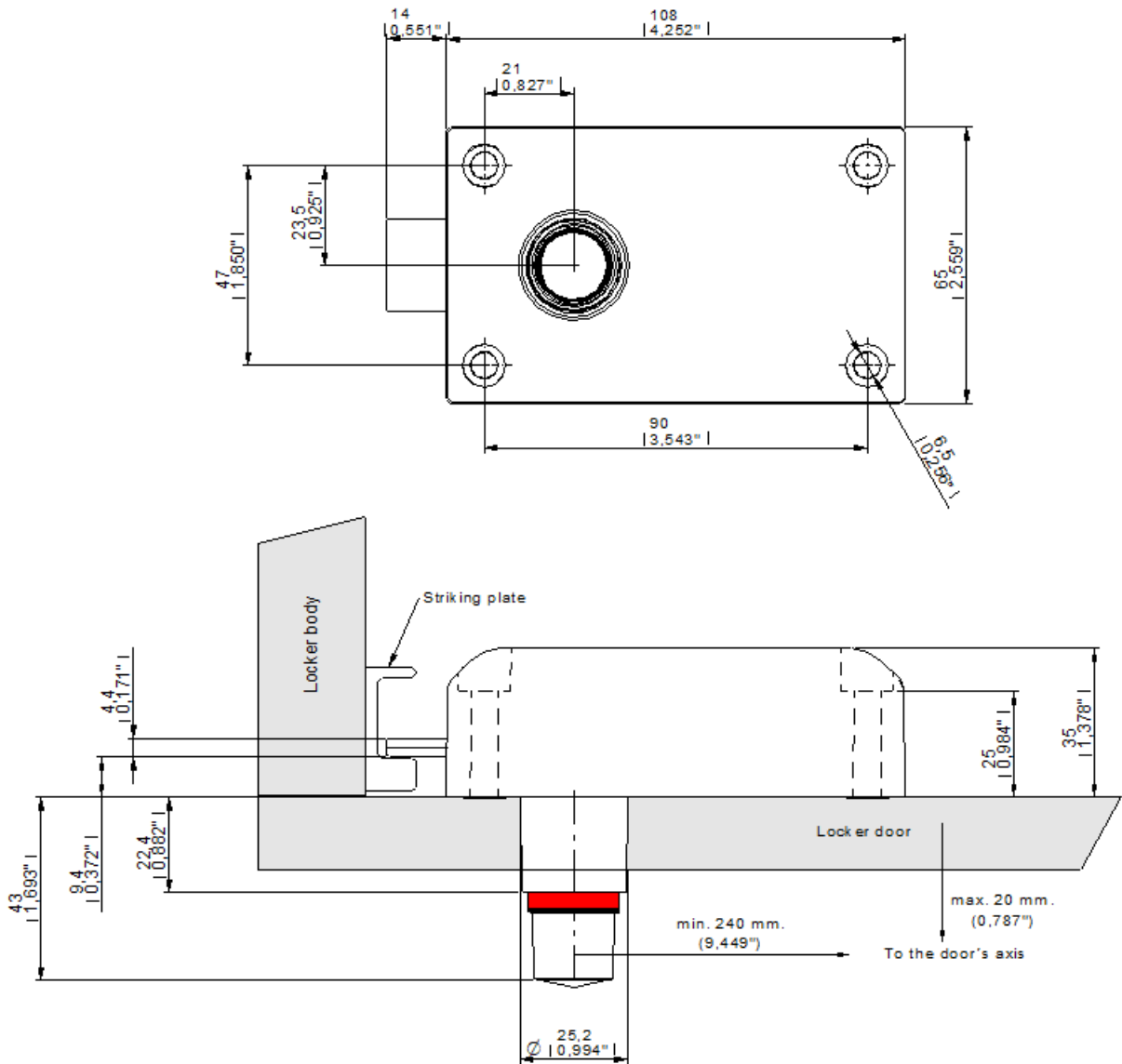

Figure 4. Measurements of OTS Batteryless lock in mm (inches).

oymar

**OJMAR HQ**

Pol. Ind. Lerun s/n  
20870 ELGOIBAR - SPAIN

**OJMAR US**

17155 Von Karman Ave, S11  
92614 IRVINE CA - USA